

Bidirectional protection wattmeters

Analogue indicator to measure three-phase current



Description

Electronic instrument on the front panel (96x96) used to protect generators against overloads and inverse power. The instrument is composed of a power converter with an analogue output connected to the needle indicator with 2 relays. The unit measures and indicates the system's power constantly (measurement in 4 quadrants), sending an alarm signal when the power exceeds the set trip values. The alarm is indicated by activating the output relays. The two LEDs on the front panel can be used to view the status of output relays. The scale is exchangeable.

Application

- The instrument has two independent relays: an overload and an inverse power relay.

Overload protection

The protection has these characteristics:

- Trip point adjustable between 0 and 100% of the scale base power
- Hysteresis adjustable between 1 and 50% of the scale base
- Delay adjustable between 0 and 30 s
- Inverse power protection. With various generators connected in parallel, one can start consuming power and working as a motor, under determined situations ("motorization"). The relay is activated when the circumstances are met.

The protection system has the following characteristics: Trip point adjustable between 0 and 20% of the scale base power

- Delay is adjustable between 0 and 30 s.
- Relay interlocking* (latch): when the

Features

	PGR
Input circuit	
Nominal current I_n	0 ... 20 mA dc
Current measurement range	0 ... 130 % I_n
Current overload	5 I_n permanent
Impedance	3 Ω
Auxiliary power supply	
Nominal value in AC	115 / 230 / 400 V
Frequency	40 ... 80 Hz
Consumption	2.5 V·A
Nominal value in DC	9-18 / 18-36 / 36-72 / 90-140 V
Consumption	2.5 V·A
Ambient conditions	
Operating temperature	+5 ... +55 °C
Limit temperature	-25 ... +70 °C
Altitude	2000 m
Build features	
Dimensions (mm)	96 x 96 x 77.2
Weight (g)	435
Type of box	DIN rail
Degree of protection:	
Front panel	IP 52
Terminals	IP 20
Standards	BS 89, EN 60051, IEC 144, UL 94, DIN 43780, IEC 51, UNE 21318

alarm condition is met, the relay is activated until the instrument's auxiliary power supply is not shut down (even when the alarm conditions disappear)

- Fault security: the relay bypass position is the same as when the alarm is triggered. Therefore, when the auxiliary power supply is shut down, the unit sends an alarm.

*: The system can be supplied with no relay interlocking (latch), on demand.

Bidirectional protection wattmeters

Analogue indicator to measure three-phase current



References

Single-phase wattmeters



		PGR 96 M
Converter (See catalogue M2)	CW-M	
Class	1,5	
Scale	90° , P2	
U / I	100 ... 500 V	
100...500 V	.../5 A (*)	M14721

Three-phase wattmeters



		PGR 96E	PGR 96A	PGR 96AN
Converter (See catalogue M2)	CW-TE	CW-TA	CW-TAN	
Class			1,5	
Scale			90° , P2	
U / I			100 ... 500 V	
100...500 V	.../5 A (*)	M14722	M14724	M14723

Coding table

M	1	X	X	X	X	0	0	X	X	X
Code						Internal Code	↑	↑	↑	
Scales						50				9
						60				A
						75				B
						100				C
						125				D
						150				E
						200				F
						250				G
						300				H
						400				J
						500				K
						600				L
						750				M
						800				N
						1000				P
						1200				Q
					1500				R	
					2000				S	
					2500				T	
					3000				U	
					4000				V	
					5000				W	
Current input						Standard (.../ 5 A)				0
						.../ 1 A				1
Auxiliary power supply						Standard 220...240 V				0
						380 ... 400 V 40/60 Hz				3

Dimensions

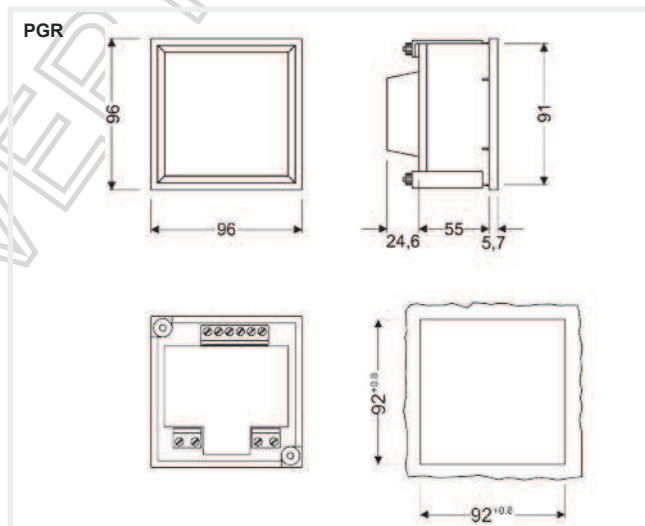

Connections

