



ENERGY METER CENTRALIZATION UNIT

LM-24-M

(Code 7 71 056)

INSTRUCTION MANUAL

(M 981 344 / 00 B)

1.- BASIC INSTRUCTIONS

1.1.- Delivery spot check

This manual is issued to help all the **LM-24-M** users to install and use it in order to get the best from it. After receiving the unit please check the following points:

- (a) Does this device corresponds to your order specifications?
- (b) Check if any damage was done during the shipment process.
- (c) Verify that it includes *One instruction manual .

1.2.- Connection procedures



The manual you hold in your hands contains information and warnings that the user should respect in order to guarantee a proper operation of all the instrument functions and keep its safety conditions.

2.- LM-24-M DESCRIPTION

Electronic energy meters, either single or three phase models, are usually provided with a pulse output proportional to the energy measured. The LM-24-M is a centralization unit of energy meters that have 24 inputs (optocoupled type) for reading pulses provided by those energy meters. Values of those pulses are saved on memory.

The LM-24-M has 24 free voltage inputs related to 24 memory records. Each record has count up to **FFFF FFFF** Hexadecimal , equivalent to a maximum record of **4.294.967.295** pulses (this registers are longs of 32 bits (4 bytes)). When this value is reached, the internal counter is reset to zero at the next pulse; so again starting the counting process. For each record of the LM-24-M , the counting zero will be given by the moment of the connection of the meter to the centralization unit.

The minimum duration of one pulse is 50 ms and the minimum time between two successive pulses is 50 ms (maximum frequency of 10 Hz).

The device has a communication serial port type RS-485, for either reading and writing actions over the 24 meters of the LM-24-M through a PC or a PLC. It use the **MODBUS** © protocol (**RTU** mode) . Functions for reading and reset to zero actions over the diverse energy meters are also available.

Several LM-24-M might be linked to a same RS-485 network. An identification number (from 1 to FF hex) can be given by the user to each device.



3.- INSTALLATION AND START-UP

The manual you hold in your hands contains information and warnings that the user should respect in order to guarantee a proper operation of all the instrument functions and keep its safety conditions.

The instrument must not be powered and used until its definitive assembly on the cabinet's door.

Whether the instrument is not used as manufacturer's specifications, the protection of the instrument can be damaged.

When any protection failure is suspected to exist (for example, it presents external visible damages), the instrument must be immediately powered off. In this case contact a qualified service representative.

3.1.- INSTALLATION

Before applying AC power to the, check following points :

a.- **Supply voltage :**

- Power supply VAC (Single phase) 50 ...60 Hz
 - **230 V a.c.**
- Frequency : 50 ... 60 Hz
- Voltage tolerance : + 15 % / --15 %
- Terminals A1 - A2 : b1 - b15 .
- Instrument burden : 5 VA

b.- Operation conditions :

- Operating temperature : 0 to 50°C
- Humidity : 25 to 80 % R.H. noncondensing

c.- Safety : Designed to meet protection class II as per EN 61010.

Mounting: 

Instrument is to be mounted on DIN rail mounting device with low dimensions.
All connections keep inside the cabinet.

Note that with the instrument powered on, the terminals could be dangerous to touching and cover opening actions or elements removal may allow accessing dangerous parts. Therefore, the instrument must not be used until this is completely installed.

The instrument must be connected to a power supply circuit protected with gl type (IEC 269) or M type fuses rated between 0.5 and 2 A. This circuit should be provided with an automatic switch or any equivalent element to disconnect the instrument from the power supply network. The supply and measuring voltage circuits will be both connected through a wire with a minimum cross-section of 1 mm².

3.2.- DESCRIPTION INPUT AND OUTPUT CONNECTION

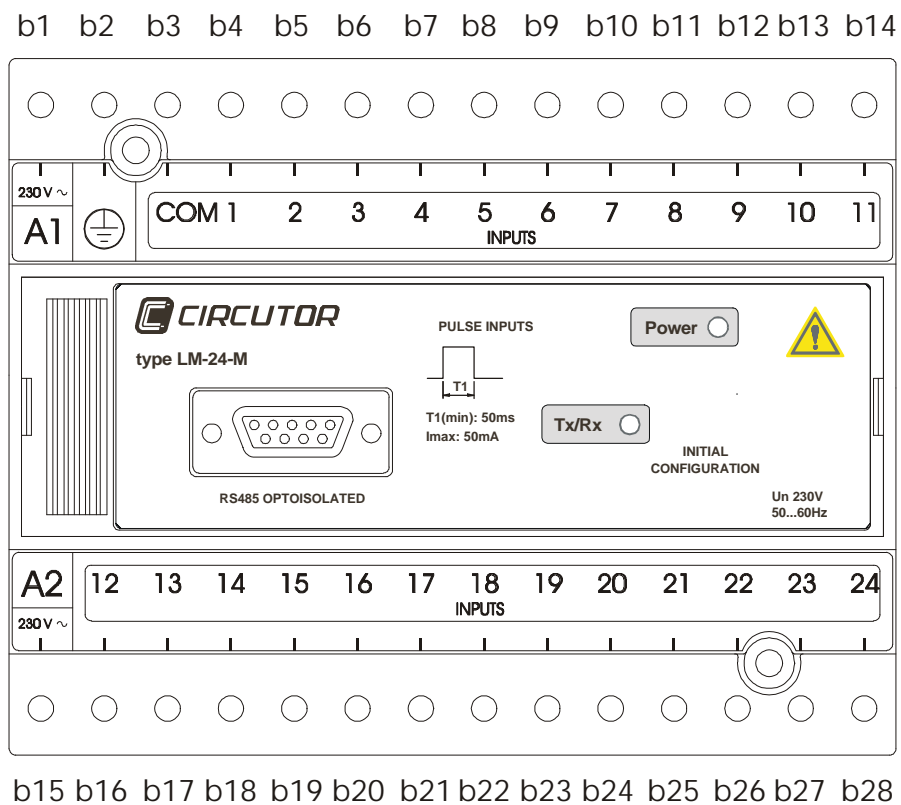

- Terminal N° b1-b15 ----- Power supply 230 V a.c.
- Terminal N° b2 ----- Earthing
- Terminal N° b3 ----- voltage free inputs common
- Terminal N° b4....b14 and b16 ... b28 ---- 24 free voltage optocoupled inputs.

3.3.- ELECTRICAL DIAGRAM (an example with the energy meter MK-63)

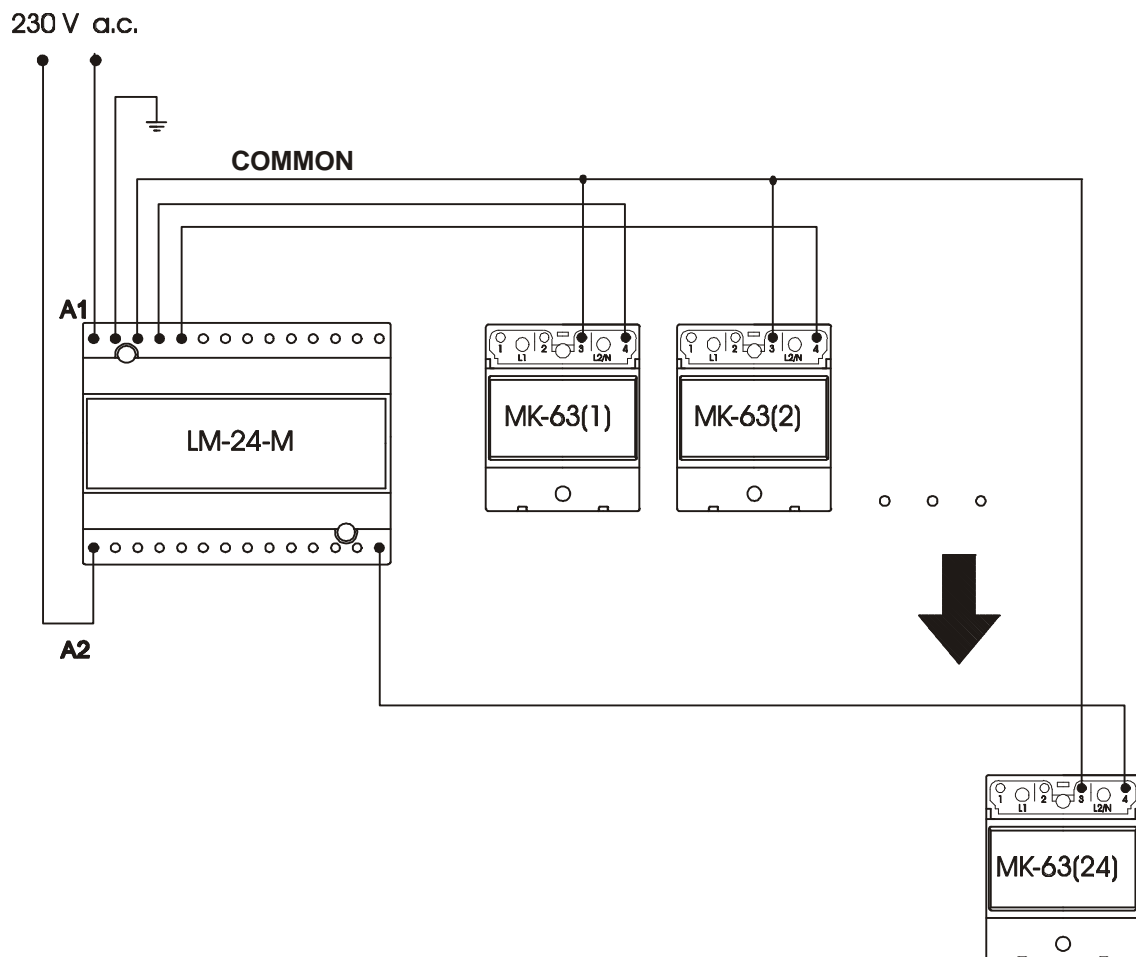

3.4.- FRONTAL COVER DESCRIPTION :

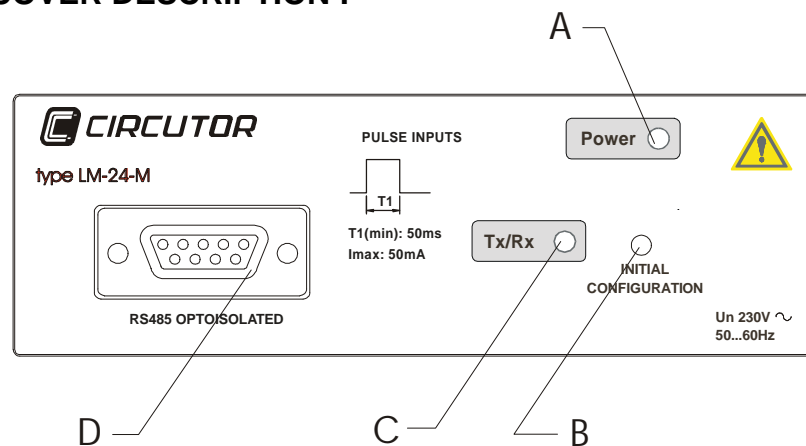

- A ----- Led POWER.
- B ----- INITIAL SET-UP push-button.
- C ----- Led Tx/Rx
- D ----- RS-485 serial port - Connector type DB-9 M

3.5.- LM-24-M CONNECTION TO PC

- Supply the instrument with 230 V a.c. (+ 15 % / --15 %) through the A1 - A2 (b1 and b15) connection terminals.

- Connect RS-485 output of the LM-24-M (1, 2 and 5 DB-9 pins) to any of the serial port of the PC. In case of a RS-232 port, use a RS-232 / RS-485 converter (code 770 208).

RS-485 - DB-9 connector

Nr. pin	Signal
1	----- TX --
2	----- TX +
5	----- GND

RS-485 connection will be carried out by means of a twisted and screened cable, with a minimum of 3 wires, with a maximum distance between the PC and the last peripheral of 1.200 m. The LM-24-M uses a RS-485 communication bus allowing up to a maximum of 32 devices in parallel (Multidot bus) per used port of the PC.

- Load *Modbus.exe* program in the PC. Follow the steps attached in the software user's instruction manual.



Available configurations are :

Baud = 1.200 & 2.400 & 4.800 & 9.600

Parity = NO/ EVEN / ODD ; bits = 8 ;

Stop bits = 1 or 2 (Stop bits = 2 , only if "No parity")

NOTE : *If the LM-24-M configuration is not known:*

Disconnect the LM-24-M supply. Pressing " INITIAL CONFIGURATION" key at the same time that it is again supplied, the RS-485 serial port is configured with following standard values :

Baud =9.600, Parity =No , bits =8 , Stop bits =1 , peripheral = FF (Hex)

- RS-485 COMMUNICATION LINK TO MULTIPLE DEVICES

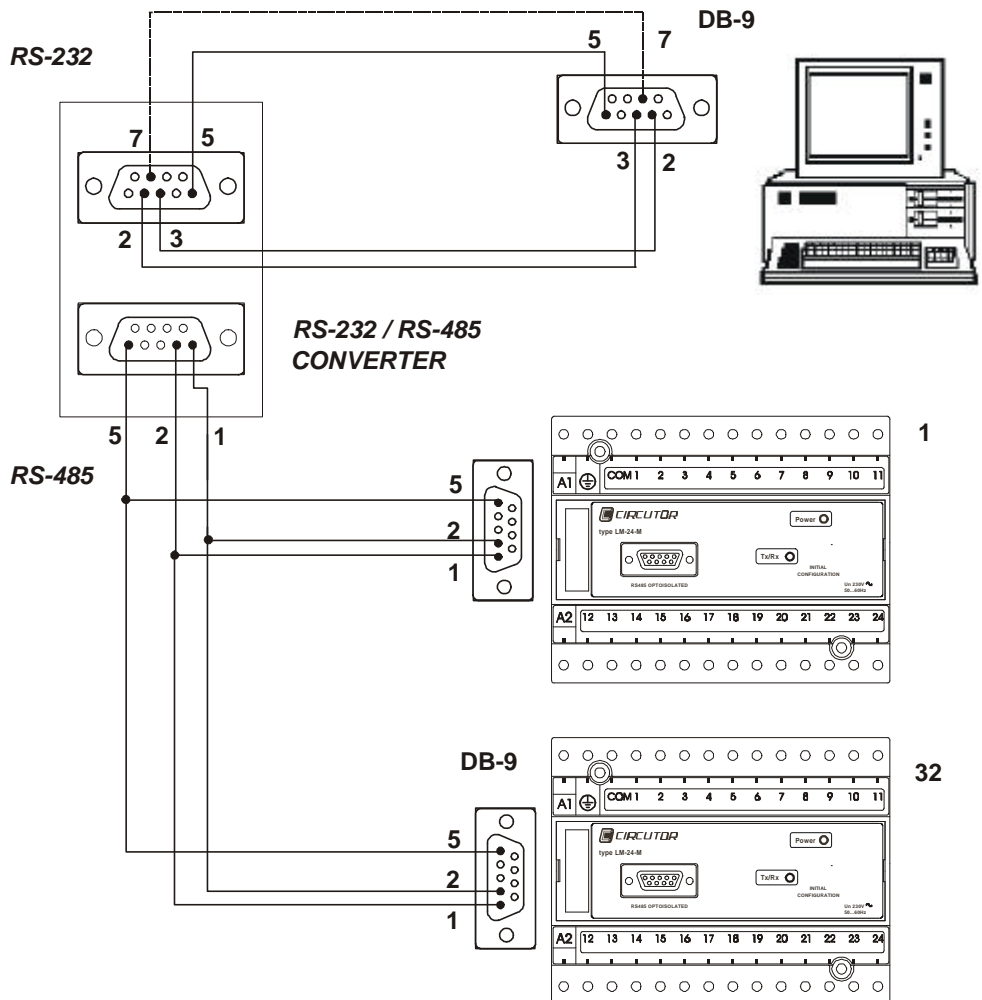

4.- TECHNICAL CHARACTERISTICS

LM-24-M Power supply :

Voltage : Single phase 230 V a.c
Voltage tolerance : +15 % / -15 %
Frequency: 50 ... 60 Hz

Power consumption : 5 VA
Operation temperature : 0 to 50 ° C

Digital inputs 24 free voltage contacts - 10 Hz
50 mA máx -5 V c.c.

Constructive characteristics :

Box type Self-extinguishing, plastic casing
Connection Metallic terminals with "posidraft" screws
Fixing Fitted onto symmetrical DIN 46277
(EN 50022) rail
Possibility of screwing them down
(Ø 4,2 mm hole)
Frontal cover Lexan
Protection Built-in relay : IP 41
Terminals : IP 20
Dimensions 140 x 70 x 110 mm (8 modules relay as per
DIN 43 880)

Security Category II , EN-61010

Isolation voltage between case and any terminal:
2500 V 50 Hz 1 min.

Isolation between set of inputs/outputs and power supply input: 1GΩ

Isolation between set of inputs/outputs and case : 1GΩ

Standards : IEC 664, VDE 0110, UL 94 , IEC 348
EN 50081-1, EN-61010-1 , EN 50082-1

Mechanical dimensions :

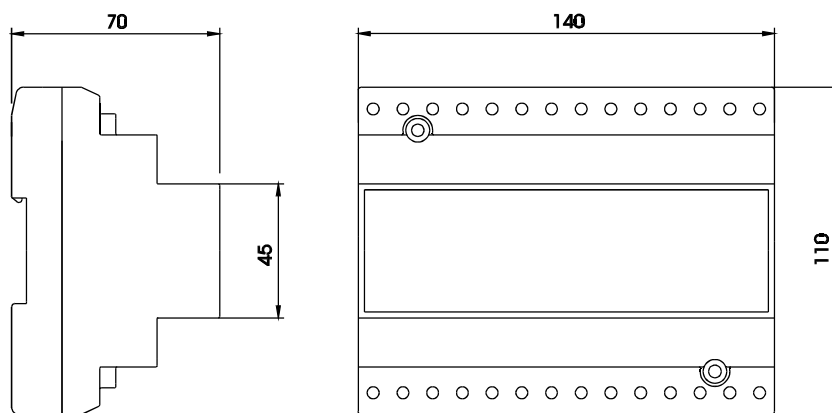

5.- SAFETY CONSIDERATIONS



All installation specification described at the previous chapters named INSTALLATION AND STARTUP, INSTALLATION MODES and SPECIFICATIONS.

Note that with the instrument powered on, the terminals could be dangerous to touching and cover opening actions or elements removal may allow accessing dangerous parts. This instrument is factory-shipped at proper operation condition.

6.- MAINTENANCE

The LM-24-M does not require any special maintenance. No adjustment, maintenance or repairing action should be done over the instrument open and powered and, should those actions are essential, high-qualified operators must perform them.

Before any adjustment, replacement, maintenance or repairing operation is carried out, the instrument must be disconnected from any power supply source.

When any protection failure is suspected to exist, the instrument must be immediately put out of service. The instrument's design allow a quick replacement in case of any failure.

7.- TECHNICAL SERVICE

For any inquiry about the instrument performance or whether any failure happens, contact to CIRCUTOR's technical service.

CIRCUTOR S.A. - Aftersales Service
c / Lepanto , 49
08223 - TERRASSA - SPAIN
Tel - 34 - 93 745 29 00
Fax - 34 - 93 745 29 14
e-mail : central@circutor.es

APPENDIX A.- LM-24-M COMMUNICATIONS (LM__ version)

A.1.- DESCRIPTION

One or some LM-24-M can be connected to a computer. With this system we can get all the parameters in one central point of reading. The LM-24-M has a serial output type RS-485. If we connect more than one LM-24-M to the same communication line, we have to assign to each of them a different code or direction (from 01 to FF hex), since the computer needs the identification of every measuring point.

PROTOCOL: Question / Answer (master-slave)



RS-485 - DB-9 connector

Nr. pin	Signal
1 -----	TX --
2 -----	TX +
5 -----	GND

A.2.- MODBUS © protocol

The LM-24-M device has the **MODBUS ©** protocol . It use the **RTU mode** (Remote terminal Unit) . Each 8-bit byte in a message contains two 4-bits hexadecimal characters.

The format for each byte in RTU mode is :

- * *Code* : **8- bit binary** , hexadecimal 0-9, A-F
Two hexadecimal characters contained in each 8-bit field of the message .
- * *Bits per Byte* : 8 data bits
- * *Error Check Field* : Cyclical Redundancy Check (**CRC**) .

MODBUS FUNCTIONS :

FUNCTION 3 Reads the n Words (16 bits- 2 bytes) . It uses this function to read all the counters of the LM-24M. This registers are longs of 32 bits ; In this case It is necessary to read two Words.
(32 bits - 4 bytes - XX XX XX XX).

FUNCTION 6 Writing of n Word . In this case it is necessary to write two Words (counters reset).
(32 bits - 4 bytes - XX XX XX XX).

Registers of the LM-24-M :

HEXA-DECIMAL address	REGISTERS
0001 Hi	Peripheral number 00-FF (hex.)
0001 Lo	Bit 7 =0 with parity, 1 No parity. Bit 6 =0 parity EVEN, 1 parity ODD. Bit 5 =0 one stop bit, 1 Two stop bits. Note : If bit 7=0 always bit 5=0. Bits 4...2 = ----- . Bits 1...0 = 00-9600, 01-4800, 10-2400 and 11-1200
0002 Lo	Bits 7...0 = State Inputs 2417
0003	Bits 15....0 = State Inputs 16 ...1
0004	program VERSION
0008- 0009	Internal Counter n°1
000A- 000B	Internal Counter n°2
000C- 000D	Internal Counter n°3
000E- 000F	Internal Counter n°4
0010- 0011	Internal Counter n°5
0012- 0013	Internal Counter n°6
0014- 0015	Internal Counter n°7

HEXA-DECIMAL address	REGISTERS
0016- 0017	Internal Counter n°8
0018- 0019	Internal Counter n°9
001A- 001B	Internal Counter n°10
001C- 001D	Internal Counter n°11
001E- 001F	Internal Counter n°12
0020- 0021	Internal Counter n°13
0022- 0023	Internal Counter n°14
0024- 0025	Internal Counter n°15
0026- 0027	Internal Counter n°16
0028- 0029	Internal Counter n°17
002A- 002B	Internal Counter n°18
002C- 002D	Internal Counter n°19
002E- 002F	Internal Counter n°20
0030- 0031	Internal Counter n°21
0032- 0033	Internal Counter n°22
0034- 0035	Internal Counter n°23
0036- 0037	Internal Counter n°24